

LIDDING MACHINE

AUTOMATIC BOX HEIGHT CHANGEOVER

PCU 20.5

PCX 20.5



↑ PCX20.5 ↑ SPEED, UP TO 1200 BOXES/HOUR

Dimensions of trays or HSC // millimeters

	WIDTH		LENGTH		HEIGHT	
	min	max	min	max	min	max
PC 20.5	200	400	300	600	100	400

MEPA
SYSTEME*USA*
MILON
INNOVATIVE PACKAGING MACHINERY

Specifications

- ▶ 2 or 4 seals lid adjusting to different box heights automatically
- ▶ Conveyor chains / Frame suited for heavy cases
- ▶ Speed : 900 to 1200 cases per hour
- ▶ Easy to use PLC with a pivoting display unit for operator.
- ▶ Precise and economical gluing by means of "hot melt" glue injector.
- ▶ 8 liter / 2.1 gallon glue tank
- ▶ Memorization of glue settings for each format.

OPTIONS ▶ Large capacity magazine ▶ 304L. stainless steel frame ▶ Automatic pellet feeder for glue melt

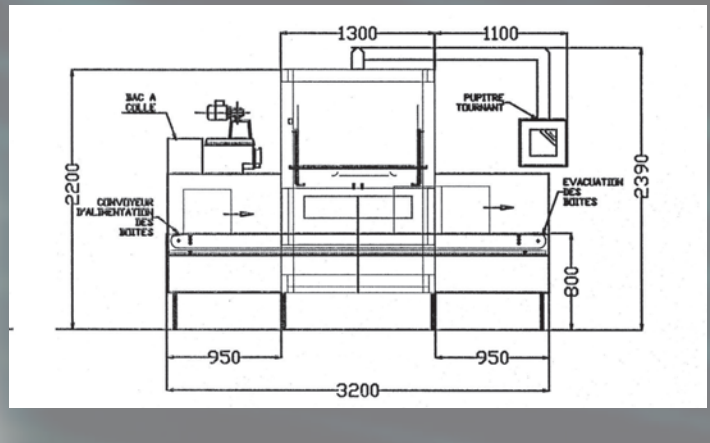
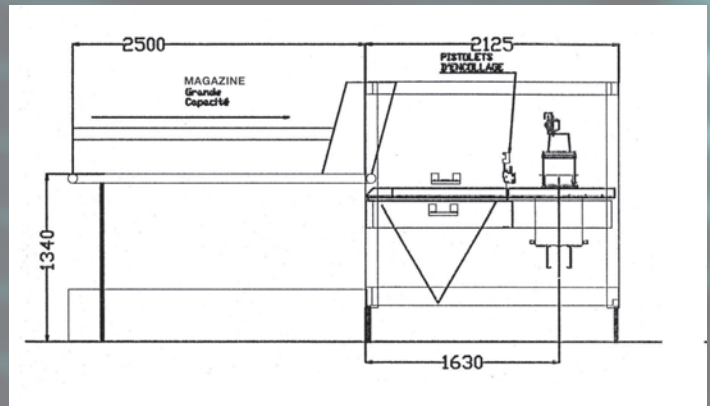

See this machine in action!

◆ 101 Washington Avenue ◆ PMB 232 ◆ Grand Haven, MI 49417 ◆
 ◆ Phone : +1-616-843-5566 ◆ info@meca-systeme.com ◆
 ◆ www.meca-systeme.com ◆

Meca
SYSTEME USA
 INNOVATIVE PACKAGING MACHINERY

Since 1980